



High Voltage Battery System

Battery-Box

HVB 5.9, 8.9, 11.8, 14.8, 17.8, 20.7, 23.7, 26.7, 29.6

HVM+ 8.3, 11.0, 13.8, 16.6, 19.3, 22.1

HVS+ 5.1, 7.7, 10.2, 12.8



Quick Start Guide

Copyright © 2023 BYD Co., Ltd. All Rights Reserved. BYD reserves the right to modify the technical datasheet and appearance of the product in the catalog without prior advice to the users. No part of this document can be copied or reproduced without BYD's permission.

www.bydenery.com +86-0755-89888888 BYD Company Limited

3009, BYD Road, Pingshan, Shenzhen, P.R.China

For the latest documents visit: www.bydenery.com



Disclaimer

1. Target Group

Instructions in this document may only be performed by qualified personnel with the following skills:

- Understand how batteries work and operate.
- Understand the working principle and operation method of the inverter.
- Know and comply with locally applicable connection requirements, standards and directives.
- Understand and follow this document and related system documentation, including all safety instructions.
- Training to handle hazards associated with the installation and operation of electrical equipment and batteries.
- Training on installation and commissioning of electrical equipment.
- For personnel engaged in special scenarios such as working at height or operating special equipment, they must be qualified by the local country or region.

2. Firefighting measures

2.1 Extinguishing media

• DRY POWDER, SAND, CARBON DIOXIDE (CO₂)

2.2 Fire precautions and protective measures

Flammable properties Lithium ion batteries contain flammable liquid electrolyte that may vent, ignite and produce sparks when subjected to high temperature (>150°C), when damaged or abused (e.g., mechanical damage or electrical overcharge). Burning cells can ignite other batteries in close proximity.

Explosion data Extreme mechanical abuse will result in rupture of the batteries. Throw into the fire will result in burning.

Special protective equipment for firefighters In the event of a fire, wear full protective clothing and self-contained breathing apparatus with full face piece operated in the pressure demand or other positive pressure mode.

NFPA Health:0 Flammability:1 Instability:0

Configure the Battery System

Through the APP, you can realize intelligent battery management, including remote data monitoring, firmware upgrade and troubleshooting.

- Android users:** Search for "BYD Energy" on Google Play or scan Android QR code to download and install.
- iPhone users:** Search for "BYD Energy" in the App Store or scan iOS QR code to download and install.



Configuration steps:



For detailed configuration steps, please refer to the user manual and APP instructions, Website: www.bydenery.com.

Requirements for Installation

1. Tools & Additional Accessories (not included in the scope of delivery)

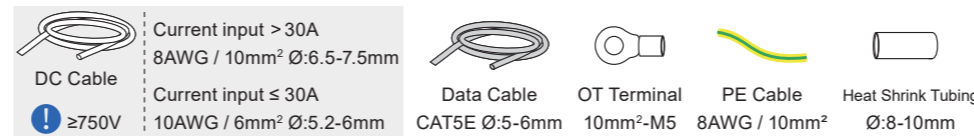
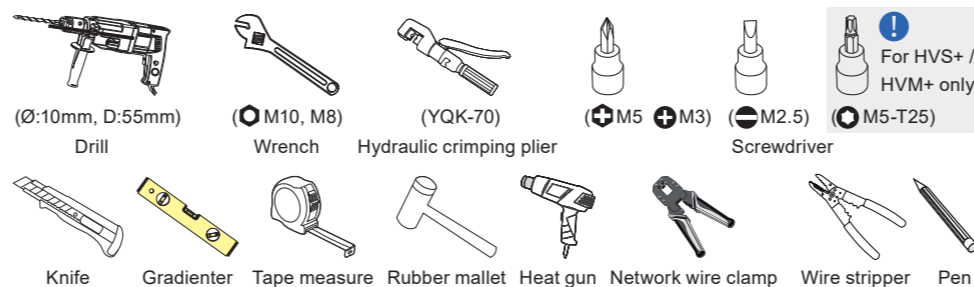

2. Safety Gear & Required Personnel

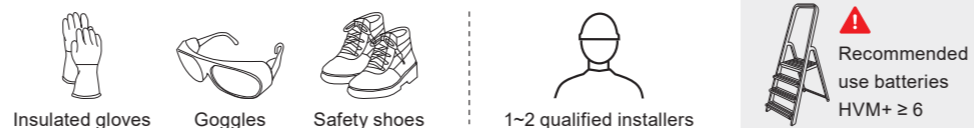

3. Installation Scene & Installation Mode



Scope of Delivery

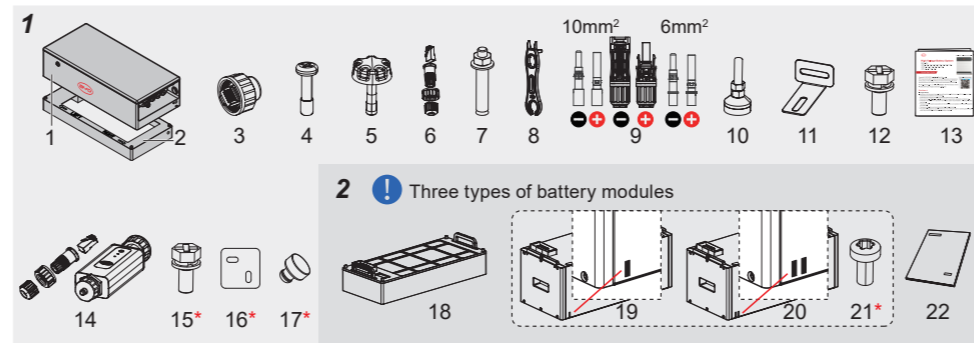

1 BCU and Base Package	3. Terminal resistor x 1	9. Power cable connector x 2	15*. Screw M5*16 x 2
1. BCU x 1	4. Screw M4*14 x 2	10. Adjustable foot x 4	16*. Hanger2 x 2
2. Base x 1	5. Knob screw x 2	11. Hanger1 x 2	17*. Rubber plug x 2
	6. Communication terminal x 2	12. Screw M5*16 x 2	
	7. Expansion screw M8 x 2	13. QSG x 1	
	8. Connector special tool x 1	14. Smart WIFI/ LAN Module x 1	
			* (for HVS+ / HVM+ only)
2 Battery Module Package	18. HVB Module x 1	20. HVM+ Module x 1	22. Attached document x 2
	19. HVS+ Module x 1	21*. Screw M5*10 x 2	

Battery System Overview

1. Structure Dimension Drawing

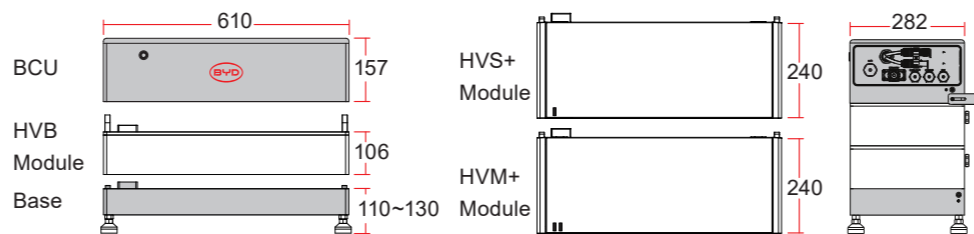

2. Functional Area Overview

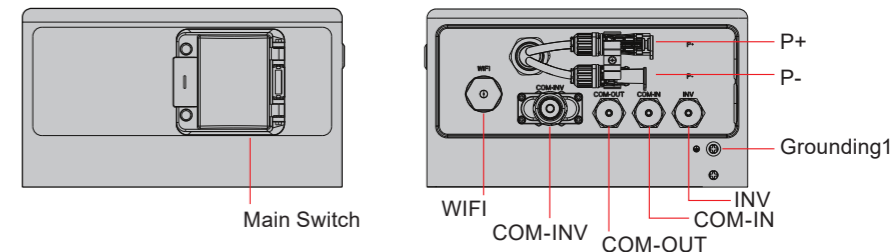

3. Battery System Description

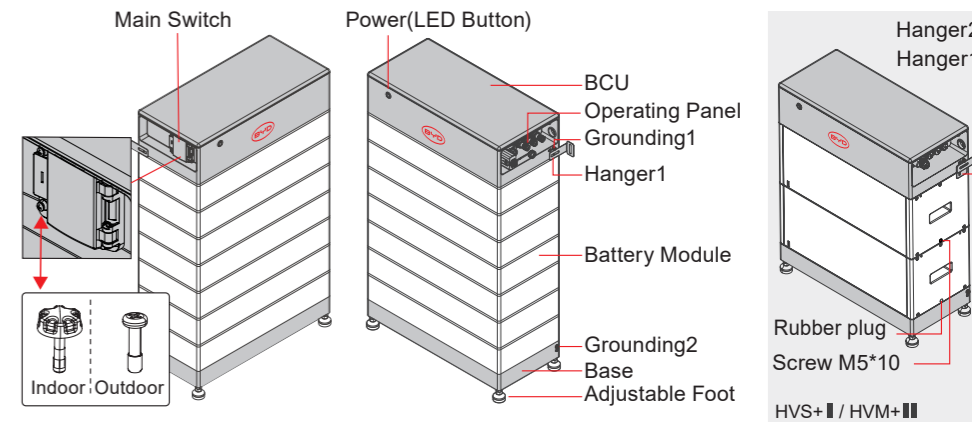

Floor Installation

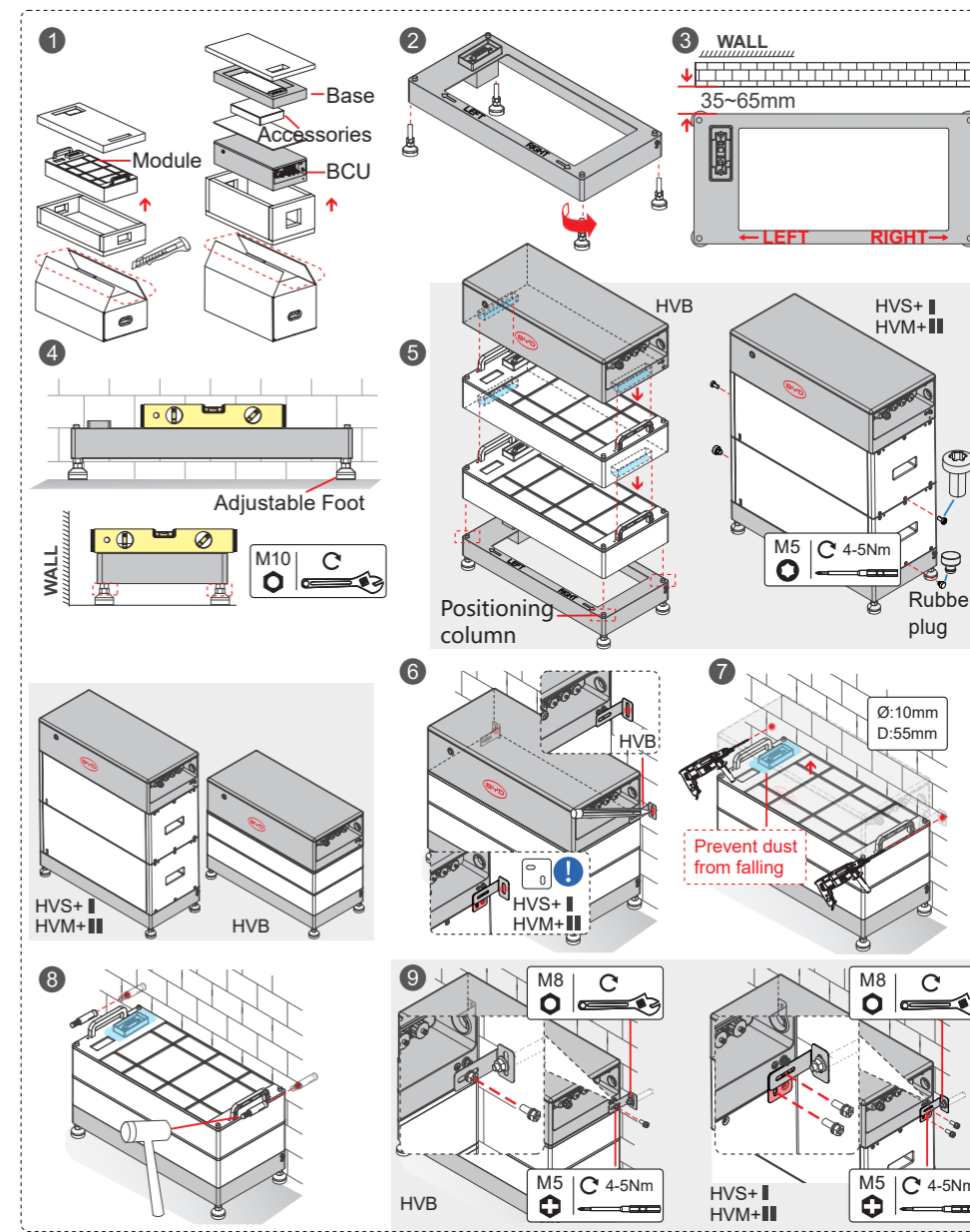

Electrical Connection

1. Connecting the PE

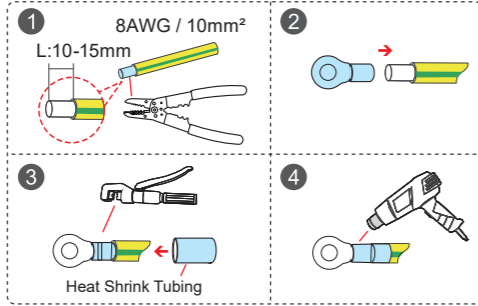
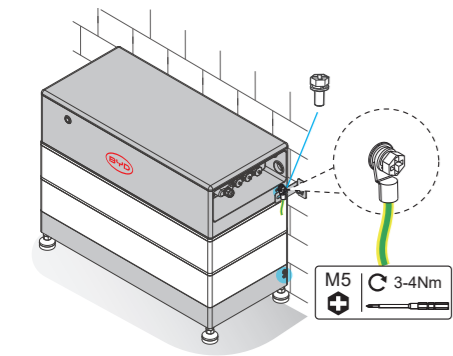

2. Connection Diagram

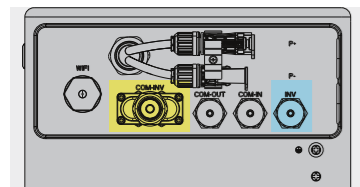

Do not crimp the unused pins when making the communication cable between the battery and the inverter.

COM-INV	INV
1 RS485A	1 RS485A
2 RS485B	2 RS485B
3 PCS_EN-	3 IGND
4 PCS_EN+	4 CAN_H
5 NC	5 CAN_L
6 IGND	6 NC
7 CAN_L	7 PCS_EN+
8 CAN_H	8 PCS_EN-

3. Connecting the Inverter cable, Smart Wifi/LAN Module*1 and Data cable*2

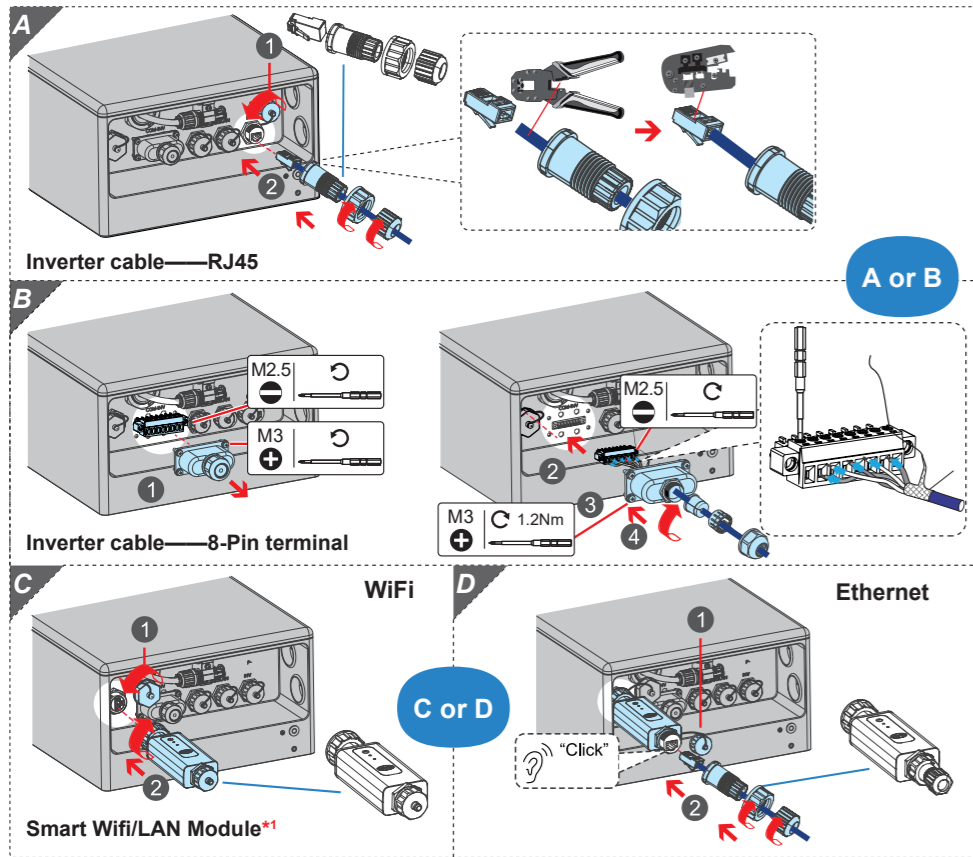

*1 The battery system doesn't have a wireless communication function. Through the USB, the battery system supports the expansion of connection with the Smart WiFi/LAN Module to implement the wireless function, and the Smart WiFi/LAN Module had obtained individual cyber security certification in accordance with EN 18031 series.

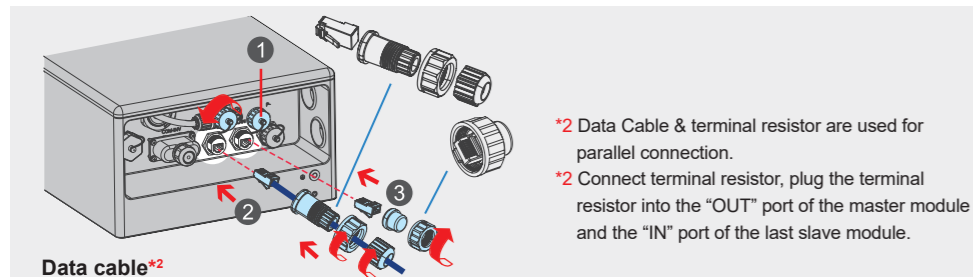

*2 Data Cable & terminal resistor are used for parallel connection.
*2 Connect terminal resistor, plug the terminal resistor into the "OUT" port of the master module and the "IN" port of the last slave module.

4. DC Connection

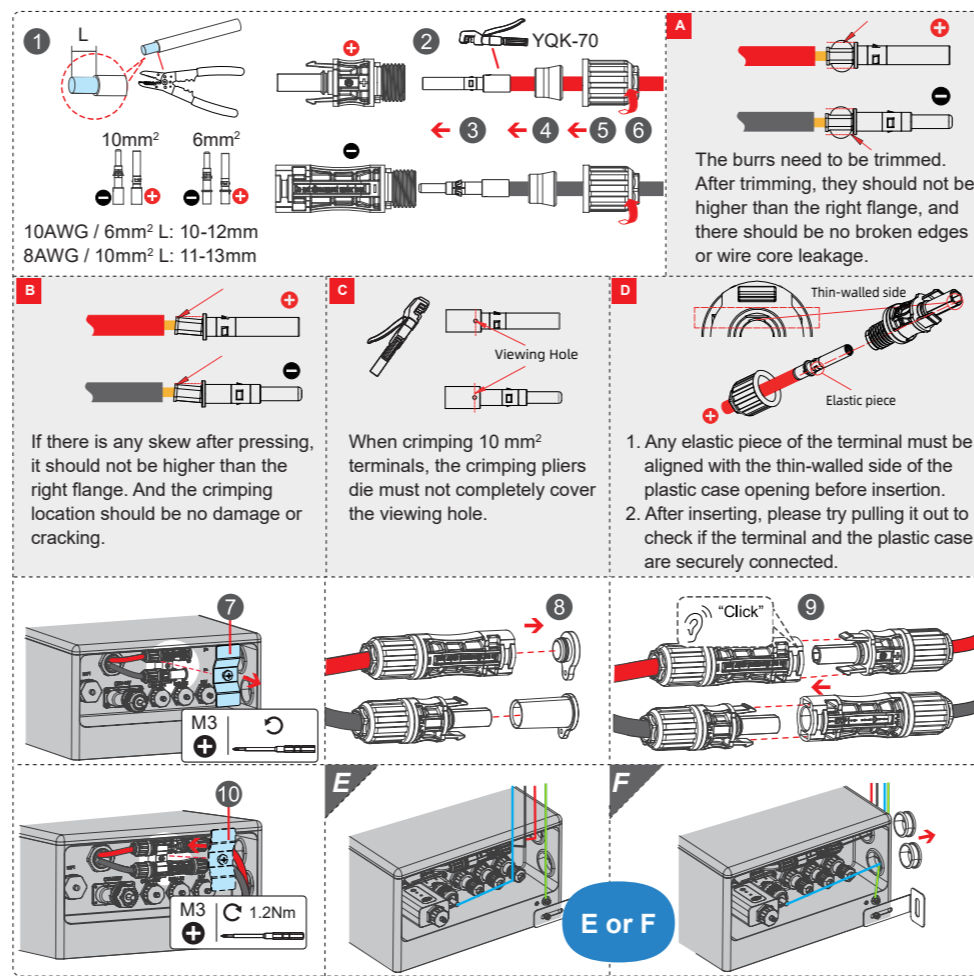

Systems Connection

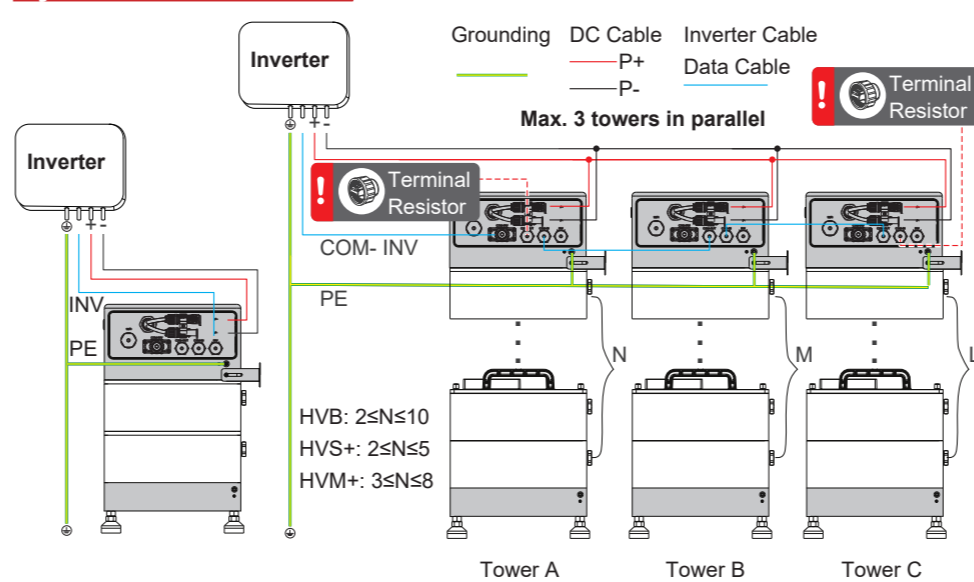

Number of Module: N = M = L (✓) or N ≠ M or N ≠ L or M ≠ L (✗)
Product Model: A = B = C (✓) or A ≠ B or A ≠ C or B ≠ C (✗)

Operation

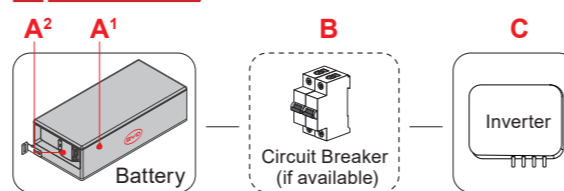

Switch on the Battery: B → A² → C
Switch off the Battery: C → A¹ 5s → B
Black Start Function: B → A² → A¹ 3s

Max. short circuit current value: 3.6kA (HVB) / 2.56kA (HVM+) / 2.42kA (HVS+), Short circuit duration: < 8ms

LED Signals

Indicator	Status	Description
Flashing white and blue alternatively	White ON OFF 0.5s	The battery system is initiating
	Blue ON OFF 0.5s	
Flashing white slowly	White ON OFF 2s	The battery system is charging
	Blue ON OFF 2s	
White light flashing	White ON OFF 1s	The battery system is discharging
	Blue ON OFF 1s	
Constant white	White ON OFF	Idle (the battery system is neither charging nor discharging).
	Blue ON OFF	
Constant blue	White ON OFF	BCU failure
	Blue ON OFF	
Constant blue and white light flashes a certain number of times	White ON OFF 2.5s	Counting from top to bottom, flashing N times, represents the Nth battery module failure. N represents 1-10 battery modules
	Blue ON OFF 0.5s	

Connection Options with Inverters

